



Low-Voltage, Quad-/Hex-/Octal-Voltage μ P Supervisors in TQFN

MAX16000-MAX16007

General Description

The MAX16000-MAX16007 are low-voltage, quad-/hex-/octal-voltage μ P supervisors in a small thin QFN package. These devices provide supervisory functions for complex multivoltage systems. The MAX16000/MAX16001/MAX16002 monitor four voltages, the MAX16003/MAX16004/MAX16005 monitor six voltages, and the MAX16006/MAX16007 monitor eight voltages.

The MAX16000/MAX16001/MAX16003/MAX16004/MAX16006 offer independent outputs for each monitored voltage. The MAX16001/MAX16002/MAX16004-MAX16007 offer a reset output that asserts whenever any of the monitored voltages fall below their respective thresholds or the manual reset input is asserted. The reset output remains asserted for the reset timeout after all voltages are above their respective thresholds and the manual reset input is deasserted. The minimum reset timeout is internally set to 140ms or can be adjusted with an external capacitor.

All open-drain outputs have internal 30 μ A pullups that eliminate the need for external pullup resistors. However, each output can be driven with an external voltage up to 5.5V. Other features offered include a manual reset input, a tolerance pin for selecting 5% or 10% input thresholds, and a margin enable function for deasserting the outputs during margin testing.

The MAX16001/MAX16002/MAX16004-MAX16007 offer a watchdog timer that asserts $\overline{\text{RESET}}$ or an independent watchdog output (MAX16005) when the watchdog timeout period (1.6s typ) is exceeded. The watchdog timer can be disabled by floating the input.

These devices are offered in 12-, 16-, 20-, and 24-lead thin QFN packages (4mm x 4mm) and are fully specified from -40°C to +125°C.

Applications

Storage Equipment
Servers
Networking/Telecommunication Equipment
Multivoltage ASICs

Selector Guide appears at end of data sheet.

Features

- ◆ Fixed Thresholds for 5V, 3.3V, 3V, 2.5V, 1.8V, 1.5V, 1.2V, and 0.9V Systems
- ◆ Adjustable Thresholds Monitor Voltages Down to 0.4V
- ◆ Open-Drain Outputs with Internal Pullups Reduce the Number of External Components
- ◆ Fixed 140ms (min) or Capacitor-Adjustable Reset Timeout
- ◆ Manual Reset, Margin Enable, and Tolerance Select Inputs
- ◆ Watchdog Timer
 - 1.6s (typ) Timeout Period
 - 54s Startup Delay After Reset (Except MAX16005)
- ◆ Independent Watchdog Output (MAX16005)
- ◆ $\overline{\text{RESET}}$ Output Indicates All Voltages Present
- ◆ Independent Voltage Monitors
- ◆ Guaranteed Correct Logic State Down to $V_{CC} = 1V$
- ◆ Small (4mm x 4mm) Thin QFN Package

Ordering Information

PART	TEMP RANGE	PIN-PACKAGE	PKG CODE
MAX16000_TC+	-40°C to +125°C	12 TQFN-EP*	T1244-4

Note: The “_” is a placeholder for the input voltage threshold. See Table 1.

+Denotes lead-free package.

For tape-and-reel, add a “T” after the “+.” Tape-and-reel are offered in 2.5k increments.

*EP = Exposed paddle.

Ordering Information continued at end of data sheet.

Typical Operating Circuit

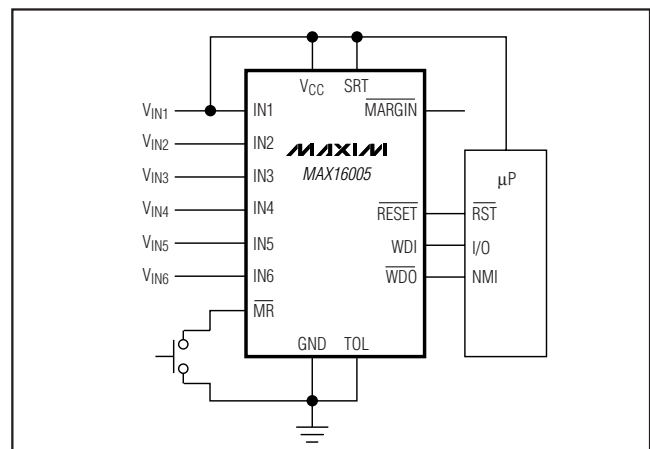

Low-Voltage, Quad-/Hex-/Octal-Voltage μ P Supervisors in TQFN

ABSOLUTE MAXIMUM RATINGS

V_{CC} , $\overline{OUT_}$, $\overline{IN_}$, \overline{RESET} , \overline{WDO} to GND-0.3V to +6V
 TOL , \overline{MARGIN} , \overline{MR} , \overline{SRT} , \overline{WDI} , to GND-0.3V to $V_{CC} + 0.3$
 Input/Output Current (\overline{RESET} , \overline{MARGIN} ,
 \overline{SRT} , \overline{MR} , TOL , $\overline{OUT_}$, \overline{WDO} , \overline{WDI}) ± 20 mA
 Continuous Power Dissipation ($T_A = +70^\circ\text{C}$)
 12-Pin TQFN (derate 16.9mW/ $^\circ\text{C}$ above $+70^\circ\text{C}$)1349mW
 16-Pin TQFN (derate 16.9mW/ $^\circ\text{C}$ above $+70^\circ\text{C}$)1349mW
 20-Pin TQFN (derate 16.9mW/ $^\circ\text{C}$ above $+70^\circ\text{C}$)1355mW
 24-Pin TQFN (derate 16.9mW/ $^\circ\text{C}$ above $+70^\circ\text{C}$)1666mW

Operating Temperature Range-40 $^\circ\text{C}$ to +125 $^\circ\text{C}$
 Junction Temperature+150 $^\circ\text{C}$
 Storage Temperature Range-65 $^\circ\text{C}$ to +150 $^\circ\text{C}$
 Lead Temperature (soldering, 10s)+300 $^\circ\text{C}$

Stresses beyond those listed under "Absolute Maximum Ratings" may cause permanent damage to the device. These are stress ratings only, and functional operation of the device at these or any other conditions beyond those indicated in the operational sections of the specifications is not implied. Exposure to absolute maximum rating conditions for extended periods may affect device reliability.

ELECTRICAL CHARACTERISTICS

($V_{CC} = 2.0\text{V}$ to 5.5V , $T_A = -40^\circ\text{C}$ to $+125^\circ\text{C}$, unless otherwise specified. Typical values are at $V_{CC} = 3.3\text{V}$, $T_A = +25^\circ\text{C}$.) (Note 1)

PARAMETER	SYMBOL	CONDITIONS	MIN	TYP	MAX	UNITS
Operating Voltage Range	V_{CC}	(Note 2)	1.0		5.5	V
Supply Current	I_{CC}	$V_{CC} = 3.3\text{V}$, $\overline{OUT_}$, \overline{RESET} not asserted (Note 3)		45	65	μA
		$V_{CC} = 5\text{V}$, $\overline{OUT_}$, \overline{RESET} not asserted		50	70	
UVLO (Undervoltage Lockout)	V_{UVLO}	V_{CC} rising	1.62	1.8	1.98	V
$\overline{IN_}$ (See Table 1)						
Threshold Voltages ($\overline{IN_}$ Falling)	V_{TH}	5V threshold, $TOL = GND$	4.50	4.625	4.75	V
		5V threshold, $TOL = V_{CC}$	4.25	4.375	4.50	
		3.3V threshold, $TOL = GND$	2.970	3.053	3.135	
		3.3V threshold, $TOL = V_{CC}$	2.805	2.888	2.970	
		3.0V threshold, $TOL = GND$	2.70	2.775	2.85	
		3.0V threshold, $TOL = V_{CC}$	2.55	2.625	2.70	
		2.5V threshold, $TOL = GND$	2.250	2.313	2.375	
		2.5V threshold, $TOL = V_{CC}$	2.125	2.188	2.250	
		1.8V threshold, $TOL = GND$	1.62	1.665	1.71	
		1.8V threshold, $TOL = V_{CC}$	1.53	1.575	1.62	
		1.5V threshold, $TOL = GND$	1.350	1.388	1.425	
		1.5V threshold, $TOL = V_{CC}$	1.275	1.313	1.350	
		1.2V threshold, $TOL = GND$	1.08	1.11	1.14	
		1.2V threshold, $TOL = V_{CC}$	1.02	1.05	1.08	
		0.9V threshold, $TOL = GND$	0.810	0.833	0.855	
		0.9V threshold, $TOL = V_{CC}$	0.765	0.788	0.810	

Low-Voltage, Quad-/Hex-/Octal-Voltage μ P Supervisors in TQFN

MAX16000-MAX16007

ELECTRICAL CHARACTERISTICS (continued)

($V_{CC} = 2.0V$ to $5.5V$, $T_A = -40^{\circ}C$ to $+125^{\circ}C$, unless otherwise specified. Typical values are at $V_{CC} = 3.3V$, $T_A = +25^{\circ}C$.) (Note 1)

PARAMETER	SYMBOL	CONDITIONS	MIN	TYP	MAX	UNITS
Adjustable Threshold (IN_ Falling)	V_{TH}	TOL = GND	0.388	0.394	0.400	V
		TOL = V_{CC}	0.366	0.372	0.378	
IN_ Hysteresis	V_{TH_HYS}	IN_ rising	0.5			% V_{TH}
IN_ Input Current		Fixed thresholds	3			μA
		Adjustable thresholds	-100			+100
RESET						
Reset Timeout	t_{RP}	SRT = V_{CC}	140	200	280	ms
		CSRT = 1500pF (Note 4)	2.43	3.09	3.92	
		CSRT = 100pF	0.206			
		CSRT = open	50			
SRT Ramp Current	I_{SRT}	$V_{SRT} = 0V$	460	600	740	nA
SRT Threshold			1.173	1.235	1.293	V
SRT Hysteresis			100			mV
IN_ to Reset Delay	t_{RD}	IN_ falling	20			μs
\overline{RESET} Output-Voltage Low	V_{OL}	$V_{CC} = 3.3V$, $I_{SINK} = 10mA$, \overline{RESET} asserted	0.30			V
		$V_{CC} = 2.5V$, $I_{SINK} = 6mA$, \overline{RESET} asserted	0.30			
		$V_{CC} = 1.2V$, $I_{SINK} = 50\mu A$, \overline{RESET} asserted	0.30			
\overline{RESET} Output-Voltage High	V_{OH}	$V_{CC} \geq 2.0V$, $I_{SOURCE} = 6\mu A$, \overline{RESET} deasserted	0.8 x V_{CC}			V
\overline{MR} Input-Voltage Low	V_{IL}		0.3 x V_{CC}			V
\overline{MR} Input-Voltage High	V_{IH}		0.7 x V_{CC}			V
\overline{MR} Minimum Pulse Width			1			μs
\overline{MR} Glitch Rejection			100			ns
\overline{MR} to Reset Delay			200			ns
\overline{MR} Pullup Resistance		Pulled up to V_{CC}	12	20	28	k Ω
OUTPUTS (OUT_)						
OUT_ Output-Voltage Low	V_{OL}	$V_{CC} = 3.3V$, $I_{SINK} = 2mA$	0.30			V
		$V_{CC} = 2.5V$, $I_{SINK} = 1.2mA$	0.30			
OUT_ Output-Voltage High	V_{OH}	$V_{CC} \geq 2.0V$, $I_{SOURCE} = 6\mu A$	0.8 x V_{CC}			V
IN_ to OUT_ Propagation Delay	t_D	($V_{TH} + 100mV$) to ($V_{TH} - 100mV$)	20			μs

Low-Voltage, Quad-/Hex-/Octal-Voltage μ P Supervisors in TQFN

ELECTRICAL CHARACTERISTICS (continued)

($V_{CC} = 2.0V$ to $5.5V$, $T_A = -40^\circ C$ to $+125^\circ C$, unless otherwise specified. Typical values are at $V_{CC} = 3.3V$, $T_A = +25^\circ C$). (Note 1)

PARAMETER	SYMBOL	CONDITIONS	MIN	TYP	MAX	UNITS
REFERENCE OUTPUT (MAX16005 Only)						
Reference Short-Circuit Current		Shorted to GND		0.8		mA
Reference Output Accuracy	V_{REF}	No load	1.200	1.235	1.270	V
Line Regulation				0.005		% / V
Reference Load Regulation		Sourcing, $0 \leq I_{REF} \leq 40\mu A$		10		Ω
WATCHDOG TIMER (MAX16001/MAX16002/MAX16004-MAX16007)						
WDI Input-Voltage Low	V_{IL}				$0.3 \times V_{CC}$	V
WDI Input-Voltage High	V_{IH}		$0.7 \times V_{CC}$			V
WDI Pulse Width		(Note 5)	50			ns
Watchdog Timeout Period	t_{WDI}		1.12	1.6	2.40	s
Watchdog Startup Period		MAX16001/2/4/6/7	35	54	72	s
Watchdog Input Current		$V_{WDI} = 0$ to V_{CC} (Note 5)	-1		+1	μA
\overline{WDO} Output-Voltage Low (MAX16005 Only)	V_{OL}	$V_{CC} = 3.3V$, $I_{SINK} = 2mA$ $V_{CC} = 2.5V$, $I_{SINK} = 1.2mA$			0.30	V
\overline{WDO} Output-Voltage High (MAX16005 Only)	V_{OH}	$V_{CC} \geq 2.0V$, $I_{SOURCE} = 6\mu A$, \overline{WDO} deasserted	$0.8 \times V_{CC}$			V
DIGITAL LOGIC						
TOL Input-Voltage Low	V_{IL}				$0.3 \times V_{CC}$	V
TOL Input-Voltage High	V_{IH}		$0.7 \times V_{CC}$			V
TOL Input Current		TOL = V_{CC}			100	nA
\overline{MARGIN} Input-Voltage Low	V_{IL}				$0.3 \times V_{CC}$	V
\overline{MARGIN} Input-Voltage High	V_{IH}		$0.7 \times V_{CC}$			V
\overline{MARGIN} Pullup Resistance		Pulled up to V_{CC}	12	20	28	k Ω
\overline{MARGIN} Delay Time	t_{MD}	Rising or falling (Note 6)		50		μs

Note 1: Devices are tested at $T_A = +25^\circ C$ and guaranteed by design for $T_A = T_{MIN}$ to T_{MAX} .

Note 2: The outputs are guaranteed to be in the correct logic state down to $V_{CC} = 1V$.

Note 3: Measured with WDI, \overline{MARGIN} , and \overline{MR} unconnected.

Note 4: The minimum and maximum specifications for this parameter are guaranteed by using the worst case of the SRT ramp current and SRT threshold specifications.

Note 5: Guaranteed by design and not production tested.

Note 6: Amount of time required for logic to lock/unlock outputs from margin testing.

Low-Voltage, Quad-/Hex-/Octal-Voltage μ P Supervisors in TQFN

Typical Operating Characteristics

($V_{CC} = 3.3V$, $T_A = +25^\circ C$, unless otherwise noted.)

MAX16000-MAX16007

SUPPLY CURRENT vs. SUPPLY VOLTAGE

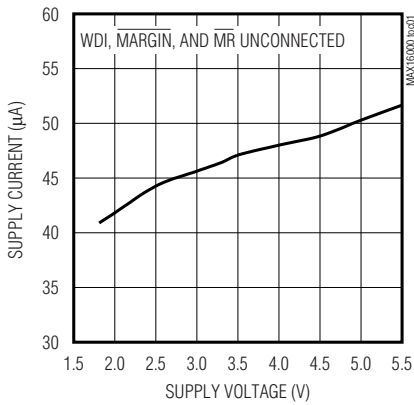

SUPPLY CURRENT vs. TEMPERATURE

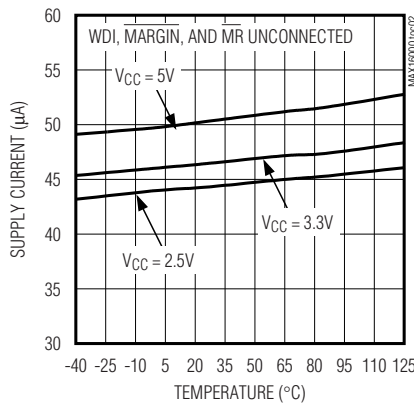

NORMALIZED THRESHOLD vs. SUPPLY VOLTAGE

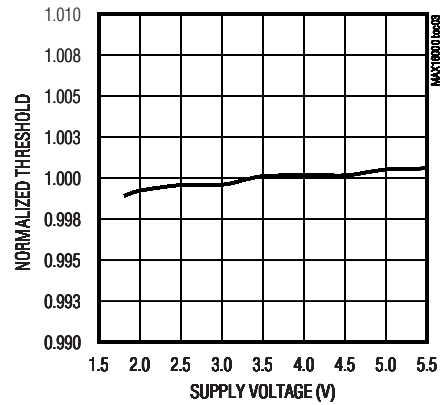

NORMALIZED THRESHOLD vs. TEMPERATURE

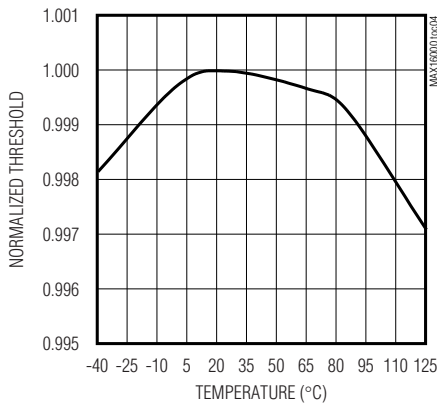

OUTPUT VOLTAGE vs. SINK CURRENT

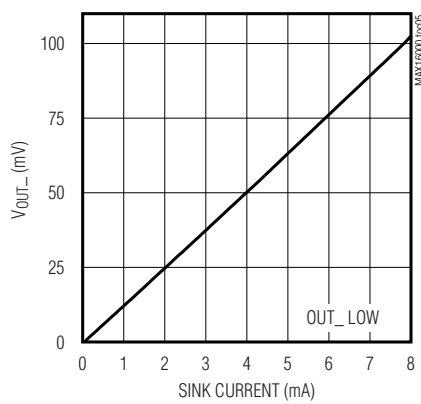

OUTPUT VOLTAGE vs. SOURCE CURRENT

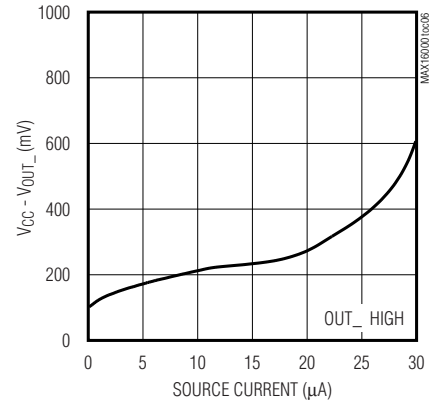

MAXIMUM TRANSIENT DURATION vs. INPUT OVERDRIVE

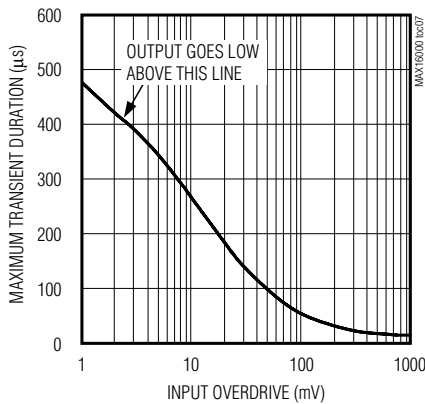

RESET TIMEOUT PERIOD vs. TEMPERATURE

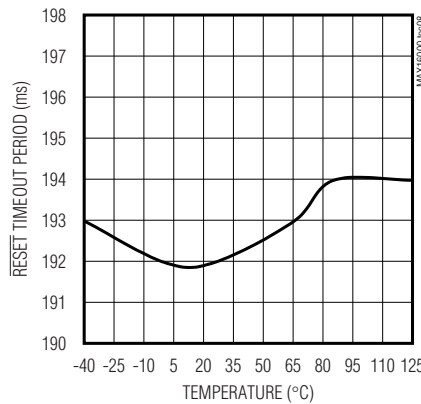

RESET TIMEOUT DELAY

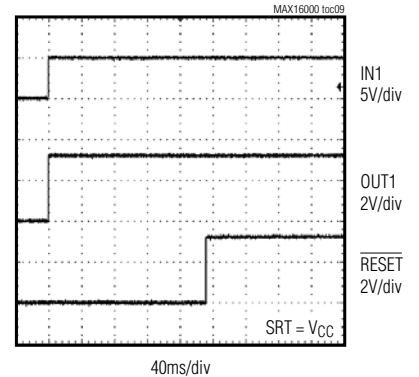

Low-Voltage, Quad-/Hex-/Octal-Voltage μ P Supervisors in TQFN

Typical Operating Characteristics (continued)

($V_{CC} = 3.3V$, $T_A = +25^\circ C$, unless otherwise noted.)

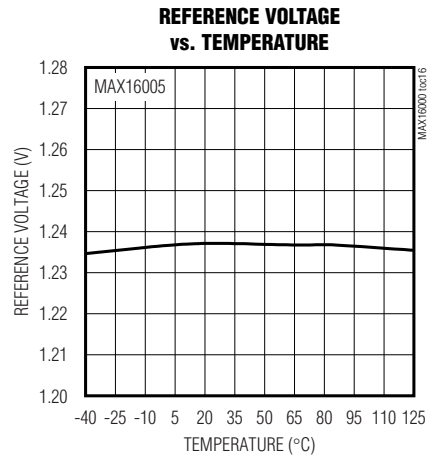
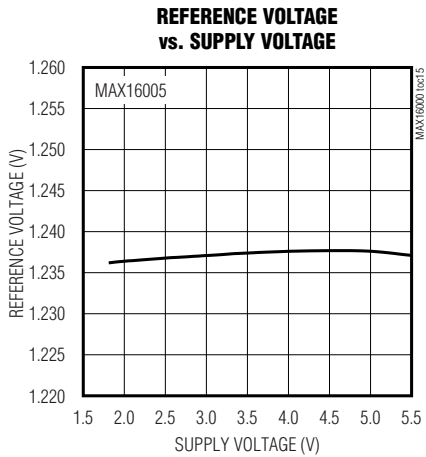
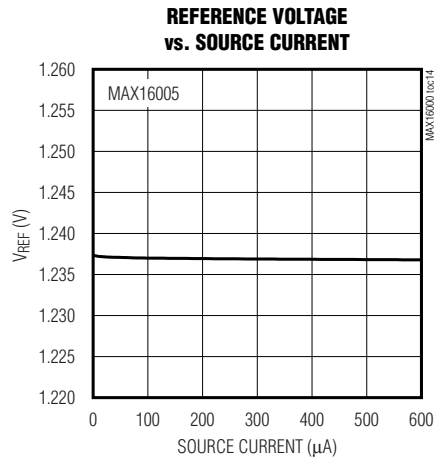
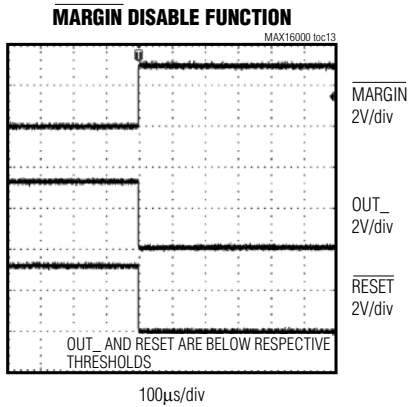
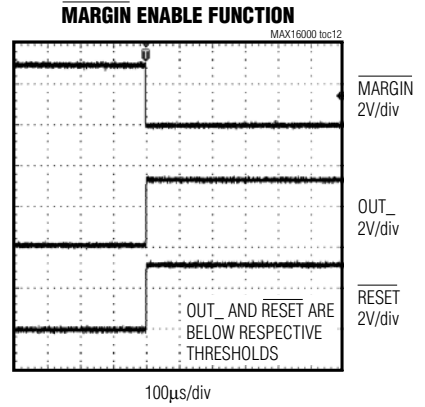
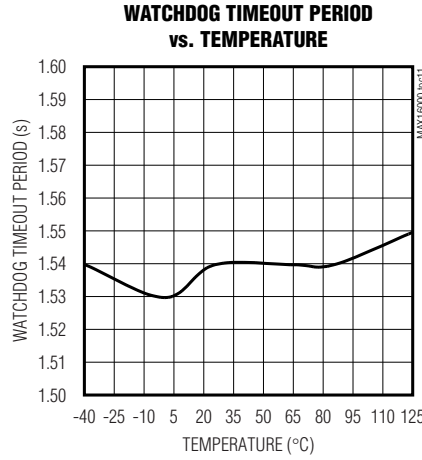
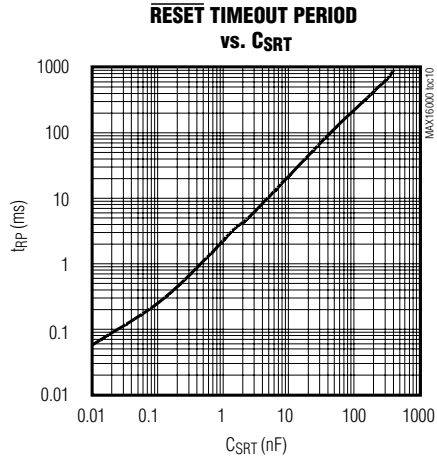

Low-Voltage, Quad-/Hex-/Octal-Voltage μ P Supervisors in TQFN

Pin Description (MAX16000/MAX16001/MAX16002)

MAX16000-MAX16007

PIN			NAME	FUNCTION
MAX16000	MAX16001	MAX16002		
1	1	1	IN3	Monitored Input Voltage 3. See Table 1 for the input voltage threshold.
2	2	2	IN4	Monitored Input Voltage 4. See Table 1 for the input voltage threshold.
3	4	4	GND	Ground
4	5	5	V _{CC}	Unmonitored Power-Supply Input
5	6	—	OUT3	Output 3. When the voltage at IN3 falls below its threshold, OUT3 goes low and stays low until the voltage at IN3 exceeds its threshold. The open-drain output has a 30 μ A internal pullup to V _{CC} .
6	7	—	OUT4	Output 4. When the voltage at IN4 falls below its threshold, OUT4 goes low and stays low until the voltage at IN4 exceeds its threshold. The open-drain output has a 30 μ A internal pullup to V _{CC} .
7	10	8	$\overline{\text{MARGIN}}$	Active-Low Manual Deassert Input. Pull $\overline{\text{MARGIN}}$ low to deassert all outputs (go into high state), regardless of the voltage at any monitored input.
8	11	—	OUT2	Output 2. When the voltage at IN2 falls below its threshold, OUT2 goes low and stays low until the voltage at IN2 exceeds its threshold. The open-drain output has a 30 μ A internal pullup to V _{CC} .
9	12	—	OUT1	Output 1. When the voltage at IN1 falls below its threshold, OUT1 goes low and stays low until the voltage at IN1 exceeds its threshold. The open-drain output has a 30 μ A internal pullup to V _{CC} .
10	14	10	IN1	Monitored Input Voltage 1. See Table 1 for the input voltage threshold.
11	15	11	IN2	Monitored Input Voltage 2. See Table 1 for the input voltage threshold.
12	16	12	TOL	Threshold Tolerance Input. Connect TOL to GND to select 5% threshold tolerance. Connect TOL to V _{CC} to select 10% threshold tolerance.
—	3	3	WDI	Watchdog Timer Input. If WDI remains low or high for longer than the watchdog timeout period, $\overline{\text{RESET}}$ is asserted. The timer clears whenever a reset is asserted or a rising or falling edge on WDI is detected. The watchdog timer enters a startup period that allows 54s for the first transition to occur before a reset. Leave WDI unconnected to disable the watchdog timer. The WDI floating-state detector uses a small 100nA current. Therefore, do not connect WDI to anything that will source or sink more than 50nA. Note that the leakage current specification for most tri-state drivers exceeds 50nA.
—	8	6	$\overline{\text{MR}}$	Active-Low Manual Reset Input. Pull $\overline{\text{MR}}$ low to assert $\overline{\text{RESET}}$ low. $\overline{\text{RESET}}$ remains low for the reset timeout period after $\overline{\text{MR}}$ is deasserted. $\overline{\text{MR}}$ is pulled up to V _{CC} through a 20k Ω resistor.
—	9	7	SRT	Set Reset Timeout Input. Connect a capacitor from SRT to GND to set the reset timeout period. The reset timeout period can be calculated as follows: Reset Timeout (s) = 2.06 x 10 ⁶ (Ω) x C _{SRT} (F). For the internal timeout period of 140ms (min), connect SRT to V _{CC} .
—	13	9	$\overline{\text{RESET}}$	Active-Low Reset Output. $\overline{\text{RESET}}$ asserts low when any of the monitored voltages falls below its respective threshold or $\overline{\text{MR}}$ is asserted. $\overline{\text{RESET}}$ remains asserted for the reset timeout period after all monitored voltages exceed their respective thresholds and $\overline{\text{MR}}$ is deasserted. This open-drain output has a 30 μ A internal pullup.
EP	EP	EP	EP	Exposed Pad. EP is internally connected to GND. Connect EP to the ground plane to provide a low thermal resistance path from the IC junction to the PC board. Do not use as the electrical connection to GND.

Low-Voltage, Quad-/Hex-/Octal-Voltage μ P Supervisors in TQFN

Pin Description (MAX16003/MAX16004/MAX16005)

PIN			NAME	FUNCTION
MAX16003	MAX16004	MAX16005		
1	1	1	IN4	Monitored Input Voltage 4. See Table 1 for the input voltage threshold.
2	2	2	IN5	Monitored Input Voltage 5. See Table 1 for the input voltage threshold.
3	3	3	IN6	Monitored Input Voltage 6. See Table 1 for the input voltage threshold.
4	5	5	GND	Ground
5	6	6	V _{CC}	Unmonitored Power-Supply Input
6	7	—	OUT4	Output 4. When the voltage at IN4 falls below its threshold, OUT4 goes low and stays low until the voltage at IN4 exceeds its threshold. The open-drain output has a 30 μ A internal pullup to V _{CC} .
7	8	—	OUT5	Output 5. When the voltage at IN5 falls below its threshold, OUT5 goes low and stays low until the voltage at IN5 exceeds its threshold. The open-drain output has a 30 μ A internal pullup to V _{CC} .
8	9	—	OUT6	Output 6. When the voltage at IN6 falls below its threshold, OUT6 goes low and stays low until the voltage at IN6 exceeds its threshold. The open-drain output has a 30 μ A internal pullup to V _{CC} .
9	12	11	$\overline{\text{MARGIN}}$	Manual Deassert Input. Pull $\overline{\text{MARGIN}}$ low to deassert all outputs (go into high state), regardless of the voltage at any monitored input.
10	13	—	OUT3	Output 3. When the voltage at IN3 falls below its threshold, OUT3 goes low and stays low until the voltage at IN3 exceeds its threshold. The open-drain output has a 30 μ A internal pullup to V _{CC} .
11	14	—	OUT2	Output 2. When the voltage at IN2 falls below its threshold, OUT2 goes low and stays low until the voltage at IN2 exceeds its threshold. The open-drain output has a 30 μ A internal pullup to V _{CC} .
12	15	—	OUT1	Output 1. When the voltage at IN1 falls below its threshold, OUT1 goes low and stays low until the voltage at IN1 exceeds its threshold. The open-drain output has a 30 μ A internal pullup to V _{CC} .
13	17	13	IN1	Monitored Input Voltage 1. See Table 1 for the input voltage threshold.
14	18	14	IN2	Monitored Input Voltage 2. See Table 1 for the input voltage threshold.
15	19	15	IN3	Monitored Input Voltage 3. See Table 1 for the input voltage threshold.

Low-Voltage, Quad-/Hex-/Octal-Voltage μ P Supervisors in TQFN

Pin Description (MAX16003/MAX16004/MAX16005) (continued)

MAX16000-MAX16007

PIN			NAME	FUNCTION
MAX16003	MAX16004	MAX16005		
16	20	16	TOL	Threshold Tolerance Input. Connect TOL to GND to select 5% threshold tolerance. Connect TOL to V _{CC} to select 10% threshold tolerance.
—	4	4	WDI	<p>Watchdog Timer Input.</p> <p>MAX16004: If WDI remains low or high for longer than the watchdog timeout period, $\overline{\text{RESET}}$ is asserted and the timer is cleared. The timer also clears whenever a reset is asserted or a rising or falling edge on WDI is detected. The watchdog timer enters a startup period that allows 54s for the first transition to occur before a reset. Leave WDI unconnected to disable the watchdog timer.</p> <p>MAX16005: If WDI remains low or high for longer than the watchdog timeout period, $\overline{\text{WDO}}$ is asserted. The timer clears whenever a rising or falling edge on WDI is detected. Leave WDI unconnected to disable the watchdog timer. The MAX16005 does not have a startup period.</p> <p>MAX16004/MAX16005: The WDI floating-state detector uses a small 100nA current. Therefore, do not connect WDI to anything that will source or sink more than 50nA. Note that the leakage current specification for most tri-state drivers exceeds 50nA.</p>
—	10	9	$\overline{\text{MR}}$	Active-Low Manual Reset Input. Pull $\overline{\text{MR}}$ low to assert $\overline{\text{RESET}}$ low. $\overline{\text{RESET}}$ remains low for the reset timeout period after $\overline{\text{MR}}$ is deasserted. $\overline{\text{MR}}$ is pulled up to V _{CC} through a 20k Ω resistor.
—	11	10	SRT	Set Reset Timeout Input. Connect a capacitor from SRT to GND to set the reset timeout period. The reset timeout period can be calculated as follows: Reset Timeout (s) = 2.06 x 10 ⁶ (Ω) x C _{SRT} (F). For the internal timeout period of 140ms (min), connect SRT to V _{CC} .
—	16	12	$\overline{\text{RESET}}$	Active-Low Reset Output. $\overline{\text{RESET}}$ asserts low when any of the monitored voltages falls below its respective threshold or $\overline{\text{MR}}$ is asserted. $\overline{\text{RESET}}$ remains asserted for the reset timeout period after all monitored voltages exceed their respective thresholds and $\overline{\text{MR}}$ is deasserted. This open-drain output has a 30 μ A internal pullup.
—	—	7	REF	Reference Output. The reference output voltage of 1.23V can source up to 40 μ A.
—	—	8	$\overline{\text{WDO}}$	Active-Low Watchdog Output. $\overline{\text{WDO}}$ asserts low whenever the watchdog timer times out or any of the IN_ inputs fall below their respective thresholds. $\overline{\text{WDO}}$ deasserts after a valid WDI transition without a reset timeout period. $\overline{\text{WDO}}$ deasserts without a timeout delay when all the IN_ inputs rise above their thresholds. Pull $\overline{\text{MR}}$ low to deassert $\overline{\text{WDO}}$. $\overline{\text{WDO}}$ remains deasserted while $\overline{\text{MR}}$ is low. The watchdog timer begins counting after the reset timeout period once $\overline{\text{MR}}$ goes high. Pull MARGIN low to deassert $\overline{\text{WDO}}$.
EP	EP	EP	EP	Exposed Pad. EP is internally connected to GND. Connect EP to the ground plane to provide a low thermal resistance path from the IC junction to the PC board. Do not use as the electrical connection to GND.

Low-Voltage, Quad-/Hex-/Octal-Voltage μ P Supervisors in TQFN

MAX16000-MAX16007

Pin Description (MAX16006/MAX16007)

PIN		NAME	FUNCTION
MAX16006	MAX16007		
1	1	IN5	Monitored Input Voltage 5. See Table 1 for the input voltage threshold.
2	2	IN6	Monitored Input Voltage 6. See Table 1 for the input voltage threshold.
3	3	IN7	Monitored Input Voltage 7. See Table 1 for the input voltage threshold.
4	4	IN8	Monitored Input Voltage 8. See Table 1 for the input voltage threshold.
5	5	WDI	Watchdog Timer Input. If WDI remains low or high for longer than the watchdog timeout period, $\overline{\text{RESET}}$ is asserted and the timer is cleared. The timer also clears whenever a reset is asserted or a rising or falling edge on WDI is detected. The watchdog timer enters a startup period that allows 54s for the first transition to occur before a reset. Leave WDI unconnected to disable the watchdog timer. The WDI floating-state detector uses a small 100nA current. Therefore, do not connect WDI to anything that will source or sink more than 50nA. Note that the leakage current specification for most tri-state drivers exceeds 50nA.
6	6	GND	Ground
7	7	V _{CC}	Unmonitored Power-Supply Input
8	—	OUT5	Output 5. When the voltage at IN5 falls below its threshold, OUT5 goes low and stays low until the voltage at IN5 exceeds its threshold. The open-drain output has a 30 μ A internal pullup to V _{CC} .
9	—	OUT6	Output 6. When the voltage at IN6 falls below its threshold, OUT6 goes low and stays low until the voltage at IN6 exceeds its threshold. The open-drain output has a 30 μ A internal pullup to V _{CC} .
10	—	OUT7	Output 7. When the voltage at IN7 falls below its threshold, OUT7 goes low and stays low until the voltage at IN7 exceeds its threshold. The open-drain output has a 30 μ A internal pullup to V _{CC} .
11	—	OUT8	Output 8. When the voltage at IN8 falls below its threshold, OUT8 goes low and stays low until the voltage at IN8 exceeds its threshold. The open-drain output has a 30 μ A internal pullup to V _{CC} .
12	10	$\overline{\text{MR}}$	Active-Low Manual Reset Input. Pull $\overline{\text{MR}}$ low to assert $\overline{\text{RESET}}$ low. $\overline{\text{RESET}}$ remains low for the reset timeout period after $\overline{\text{MR}}$ is deasserted. $\overline{\text{MR}}$ is pulled up to V _{CC} through a 20k Ω resistor.
13	11	SRT	Set Reset Timeout Input. Connect a capacitor from SRT to GND to set the reset timeout period. The reset timeout period can be calculated as follows: Reset Timeout (s) = 2.06 x 10 ⁶ (Ω) x C _{SRT} (F). For the internal timeout period of 140ms (min), connect SRT to V _{CC} .

Low-Voltage, Quad-/Hex-/Octal-Voltage μ P Supervisors in TQFN

Pin Description (MAX16006/MAX16007) (continued)

PIN		NAME	FUNCTION
MAX16006	MAX16007		
14	12	$\overline{\text{MARGIN}}$	Margin Disable Input. Pull $\overline{\text{MARGIN}}$ low to deassert all outputs (go into high state), regardless of the voltage at any monitored input.
15	—	OUT4	Output 4. When the voltage at IN4 falls below its threshold, OUT4 goes low and stays low until the voltage at IN4 exceeds its threshold. The open-drain output has a 30 μ A internal pullup to V _{CC} .
16	—	OUT3	Output 3. When the voltage at IN3 falls below its threshold, OUT3 goes low and stays low until the voltage at IN3 exceeds its threshold. The open-drain output has a 30 μ A internal pullup to V _{CC} .
17	—	OUT2	Output 2. When the voltage at IN2 falls below its threshold, OUT2 goes low and stays low until the voltage at IN2 exceeds its threshold. The open-drain output has a 30 μ A internal pullup to V _{CC} .
18	—	OUT1	Output 1. When the voltage at IN1 falls below its threshold, OUT1 goes low and stays low until the voltage at IN1 exceeds its threshold. The open-drain output has a 30 μ A internal pullup to V _{CC} .
19	15	$\overline{\text{RESET}}$	Active-Low Reset Output. $\overline{\text{RESET}}$ asserts low when any of the monitored voltages falls below its respective threshold or $\overline{\text{MR}}$ is asserted. $\overline{\text{RESET}}$ remains asserted for the reset timeout period after all monitored voltages exceed their respective thresholds and $\overline{\text{MR}}$ is deasserted. This open-drain output has a 30 μ A internal pullup.
20	16	IN1	Monitored Input Voltage 1. See Table 1 for the input voltage threshold.
21	17	IN2	Monitored Input Voltage 2. See Table 1 for the input voltage threshold.
22	18	IN3	Monitored Input Voltage 3. See Table 1 for the input voltage threshold.
23	19	IN4	Monitored Input Voltage 4. See Table 1 for the input voltage threshold.
24	20	TOL	Threshold Tolerance Input. Connect TOL to GND to select 5% threshold tolerance. Connect TOL to V _{CC} to select 10% threshold tolerance.
—	8, 9, 13, 14	N.C.	Not Internally Connected
EP	EP	EP	Exposed Pad. EP is internally connected to GND. Connect EP to the ground plane to provide a low thermal resistance path from the IC junction to the PC board. Do not use as the electrical connection to GND.

MAX16000-MAX16007

Low-Voltage, Quad-/Hex-/Octal-Voltage μ P Supervisors in TQFN

MAX16000-MAX16007

Table 1. Input-Voltage-Threshold Selector

PART	IN1	IN2	IN3	IN4	IN5	IN6	IN7	IN8
MAX16000A	3.3	2.5	ADJ	1.8	—	—	—	—
MAX16000B	3.3	ADJ	ADJ	1.8	—	—	—	—
MAX16000C	ADJ	2.5	ADJ	1.8	—	—	—	—
MAX16000D	3.3	2.5	ADJ	ADJ	—	—	—	—
MAX16000E	ADJ	ADJ	ADJ	ADJ	—	—	—	—
MAX16001A	3.3	2.5	ADJ	1.8	—	—	—	—
MAX16001B	3.3	ADJ	ADJ	1.8	—	—	—	—
MAX16001C	ADJ	2.5	ADJ	1.8	—	—	—	—
MAX16001D	3.3	2.5	ADJ	ADJ	—	—	—	—
MAX16001E	ADJ	ADJ	ADJ	ADJ	—	—	—	—
MAX16002A	3.3	2.5	ADJ	1.8	—	—	—	—
MAX16002B	3.3	ADJ	ADJ	1.8	—	—	—	—
MAX16002C	ADJ	2.5	ADJ	1.8	—	—	—	—
MAX16002D	3.3	2.5	ADJ	ADJ	—	—	—	—
MAX16002E	ADJ	ADJ	ADJ	ADJ	—	—	—	—
MAX16003A	3.3	2.5	ADJ	1.8	ADJ	ADJ	—	—
MAX16003B	3.3	ADJ	ADJ	1.8	ADJ	ADJ	—	—
MAX16003C	3.3	2.5	ADJ	ADJ	ADJ	ADJ	—	—
MAX16003D	ADJ	2.5	ADJ	1.8	ADJ	ADJ	—	—
MAX16003E	ADJ	ADJ	ADJ	ADJ	ADJ	ADJ	—	—
MAX16004A	3.3	2.5	ADJ	1.8	ADJ	ADJ	—	—
MAX16004B	3.3	ADJ	ADJ	1.8	ADJ	ADJ	—	—
MAX16004C	3.3	2.5	ADJ	ADJ	ADJ	ADJ	—	—
MAX16004D	ADJ	2.5	ADJ	1.8	ADJ	ADJ	—	—
MAX16004E	ADJ	ADJ	ADJ	ADJ	ADJ	ADJ	—	—
MAX16005A	3.3	2.5	ADJ	1.8	ADJ	ADJ	—	—
MAX16005B	3.3	ADJ	ADJ	1.8	ADJ	ADJ	—	—
MAX16005C	3.3	2.5	ADJ	ADJ	ADJ	ADJ	—	—
MAX16005D	ADJ	2.5	ADJ	1.8	ADJ	ADJ	—	—
MAX16005E	ADJ	ADJ	ADJ	ADJ	ADJ	ADJ	—	—
MAX16006A	3.3	2.5	ADJ	1.8	ADJ	ADJ	ADJ	ADJ
MAX16006B	3.3	ADJ	ADJ	1.8	ADJ	ADJ	ADJ	ADJ
MAX16006C	3.3	2.5	ADJ	ADJ	ADJ	ADJ	ADJ	ADJ
MAX16006D	ADJ	2.5	ADJ	1.8	ADJ	ADJ	ADJ	ADJ
MAX16006E	ADJ	ADJ	ADJ	ADJ	ADJ	ADJ	ADJ	ADJ
MAX16006F	5.0	3.3	3.0	2.5	1.8	1.5	1.2	0.9
MAX16007A	3.3	2.5	ADJ	1.8	ADJ	ADJ	ADJ	ADJ
MAX16007B	3.3	ADJ	ADJ	1.8	ADJ	ADJ	ADJ	ADJ
MAX16007C	3.3	2.5	ADJ	ADJ	ADJ	ADJ	ADJ	ADJ
MAX16007D	ADJ	2.5	ADJ	1.8	ADJ	ADJ	ADJ	ADJ
MAX16007E	ADJ	ADJ	ADJ	ADJ	ADJ	ADJ	ADJ	ADJ

Note: Other fixed thresholds may be available. Contact factory for availability.

Low-Voltage, Quad-/Hex-/Octal-Voltage μ P Supervisors in TQFN

Functional Diagrams

MAX16000-MAX16007

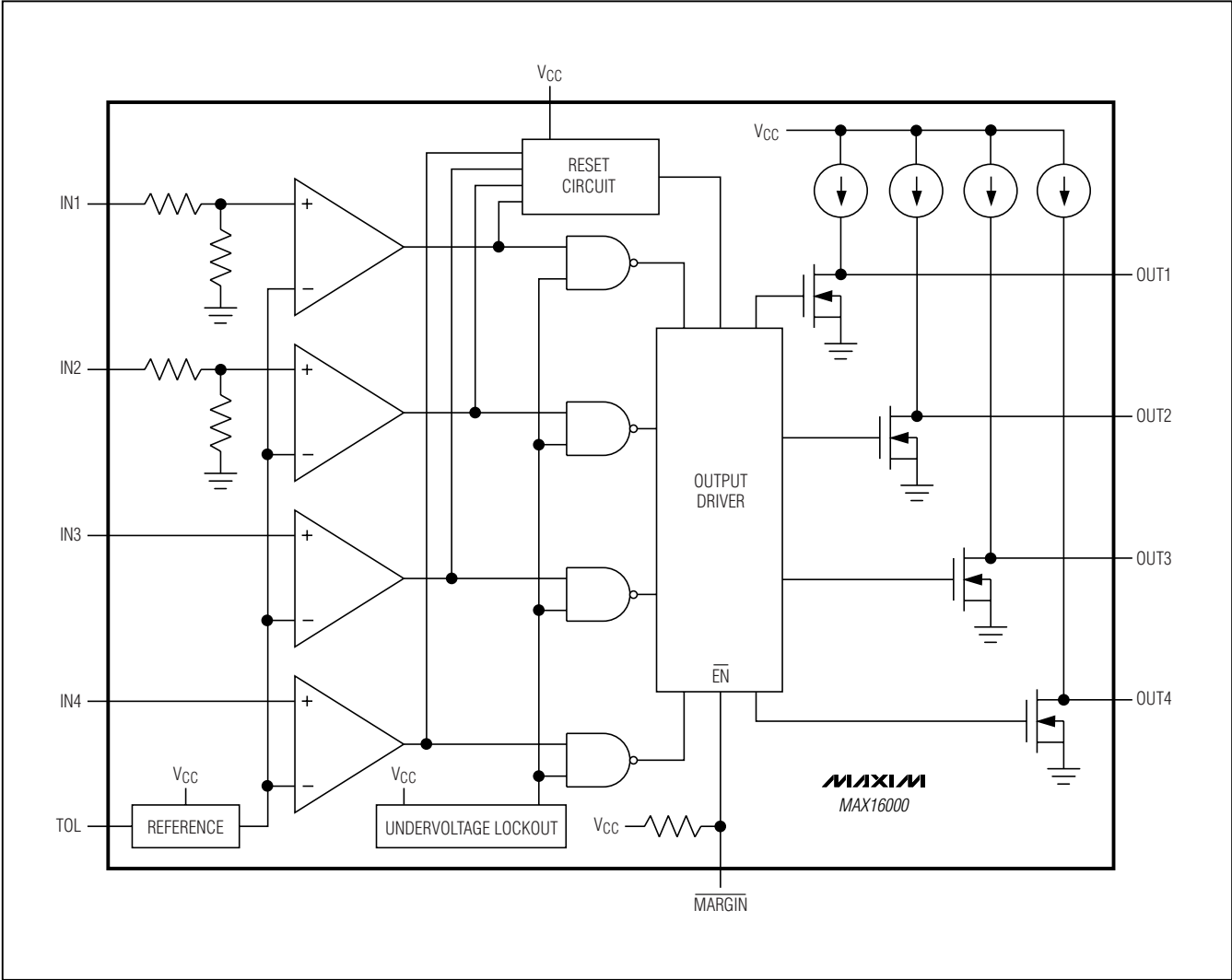

Figure 1. MAX16000D Functional Diagram

Low-Voltage, Quad-/Hex-/Octal-Voltage μ P Supervisors in TQFN

MAX16000-MAX16007

Functional Diagrams (continued)

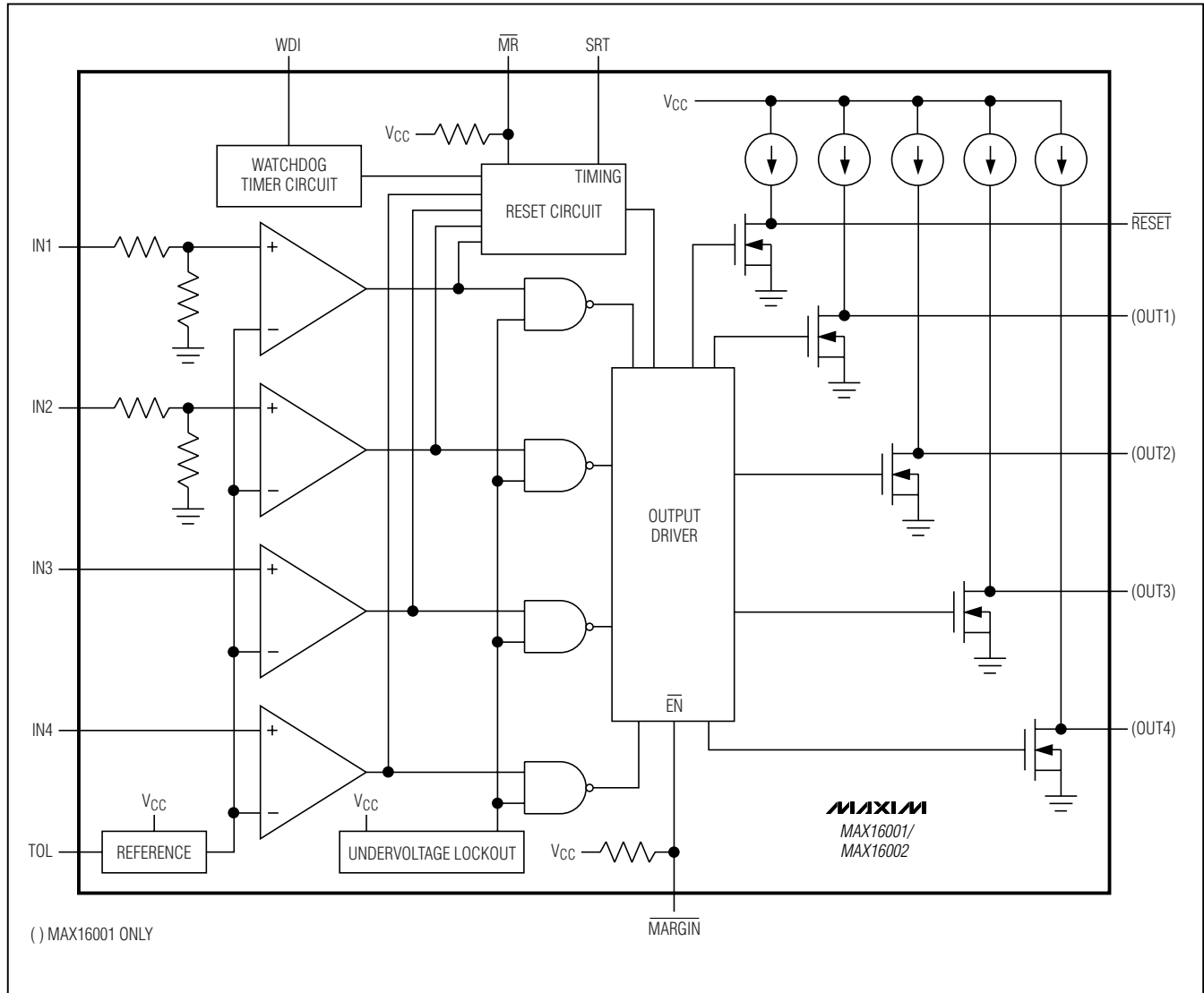

Figure 2. MAX16001D/MAX16002D Functional Diagram

Low-Voltage, Quad-/Hex-/Octal-Voltage μ P Supervisors in TQFN

Functional Diagrams (continued)

MAX16000-MAX16007

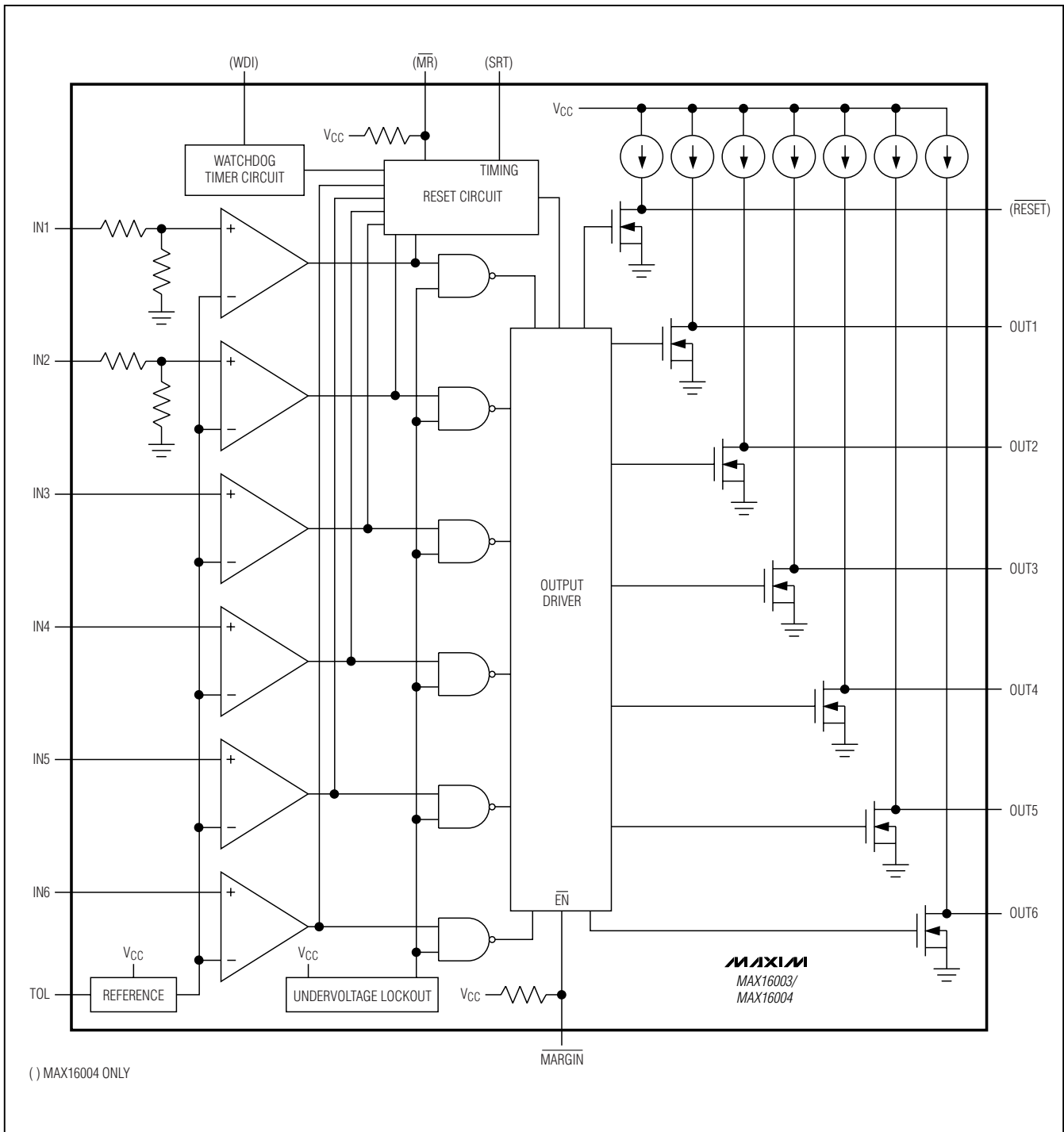

Figure 3. MAX16003C/MAX16004C Functional Diagram

Low-Voltage, Quad-/Hex-/Octal-Voltage μ P Supervisors in TQFN

Functional Diagrams (continued)

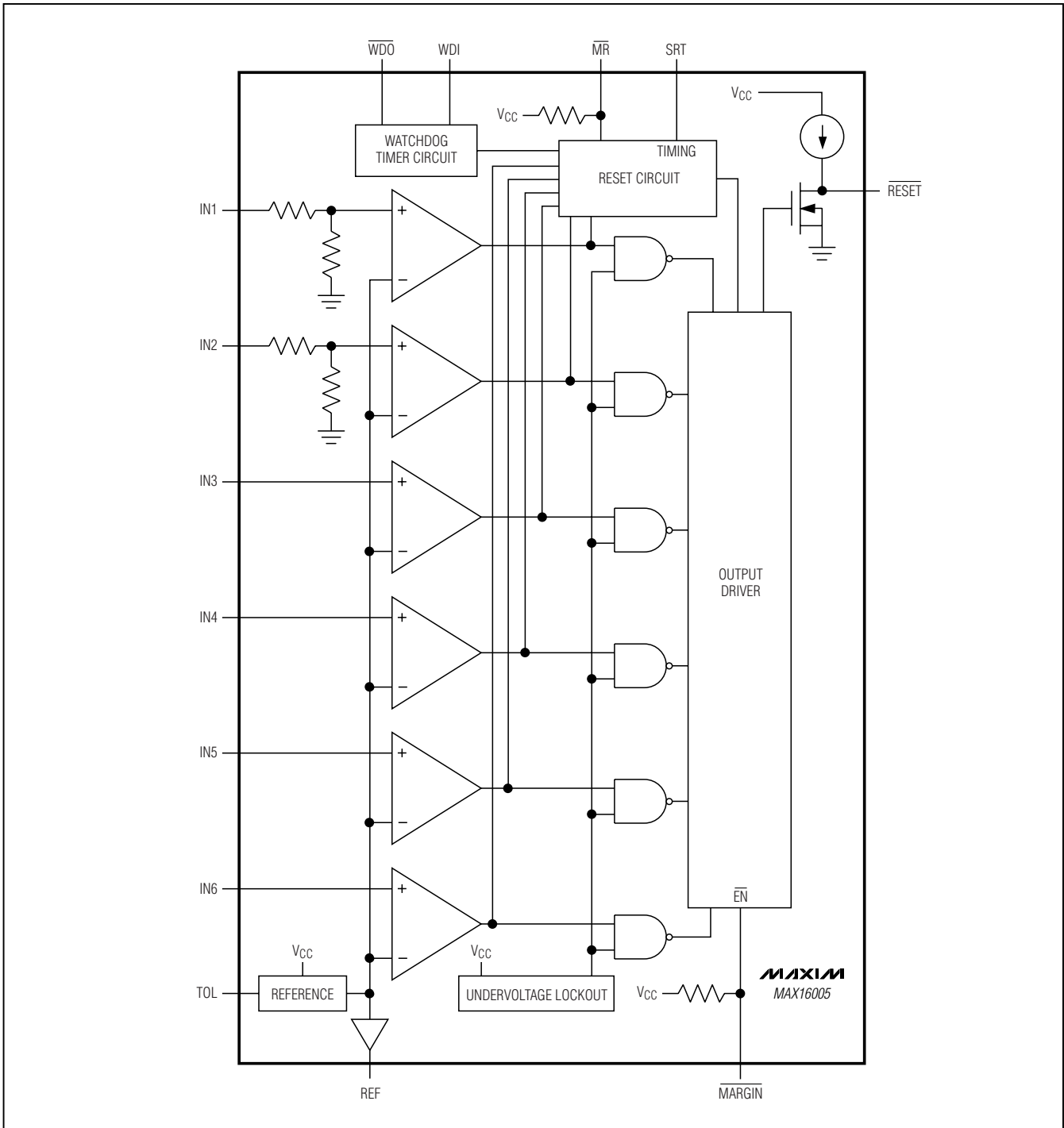

Figure 4. MAX16005C Functional Diagram

Low-Voltage, Quad-/Hex-/Octal-Voltage μ P Supervisors in TQFN

Functional Diagrams (continued)

MAX16000-MAX16007

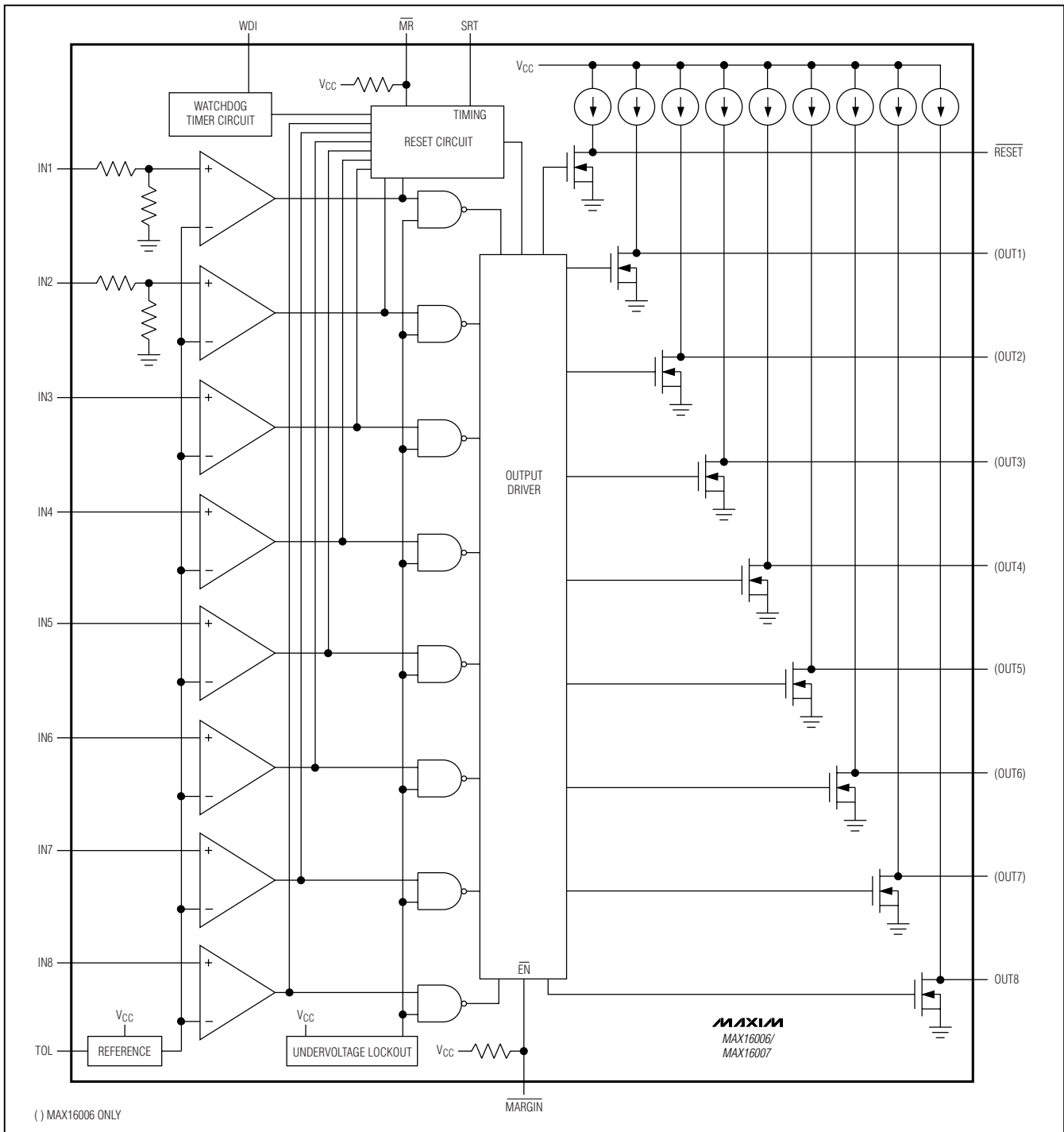

Figure 5. MAX16006C/MAX16007C Functional Diagram

Low-Voltage, Quad-/Hex-/Octal-Voltage μ P Supervisors in TQFN

Detailed Description

The MAX16000–MAX16007 are low-voltage, quad-/hex-/octal-voltage μ P supervisors in a small thin QFN package. These devices provide supervisory functions for complex multivoltage systems. The MAX16000/MAX16001/MAX16002 monitor four voltages, the MAX16003/MAX16004/MAX16005 monitor six voltages, and the MAX16006/MAX16007 monitor eight voltages.

The MAX16000/MAX16001/MAX16003/MAX16004/MAX16006 offer independent outputs for each monitored voltage. The MAX16001/MAX16002/MAX16004–MAX16007 offer a reset output that asserts whenever any of the monitored voltages fall below their respective thresholds or the manual reset input is asserted. The reset output remains asserted for the reset timeout after all voltages are above their respective thresholds and the manual reset input is deasserted. The minimum reset timeout is internally set to 140ms or can be adjusted with an external capacitor.

All open-drain outputs have internal 30 μ A pullups that eliminate the need for external pullup resistors. However, each output can be driven with an external voltage up to 5.5V. Other features offered include a manual reset input, a tolerance pin for selecting 5% or 10% input thresholds, and a margin enable function for deasserting the outputs during margin testing.

The MAX16001/MAX16002/MAX16004–MAX16007 offer a watchdog timer that asserts $\overline{\text{RESET}}$ or an independent watchdog output (MAX16005) when the watchdog timeout period (1.6s typ) is exceeded. The watchdog timer can be disabled by floating the input.

Applications Information

Undervoltage-Detection Circuit

The open-drain outputs of the MAX16000–MAX16007 can be configured to detect an undervoltage condition. Figure 6 shows a configuration where an LED turns on when the comparator output is low, indicating an undervoltage condition. These devices can also be used in applications such as system supervisory monitoring, multivoltage level detection, and V_{CC} bar-graph monitoring (Figure 7).

Tolerance (TOL)

The MAX16000–MAX16007 feature a pin-selectable threshold tolerance. Connect TOL to GND to select 5% threshold tolerance. Connect TOL to V_{CC} to select 10% threshold tolerance.

Window Detection

A window detector circuit uses two auxiliary inputs in the configuration shown in Figure 8. External resistors set the two threshold voltages of the window detector circuit. External logic gates create the OUT signal. The window detection width is the difference between the threshold voltages (Figure 9).

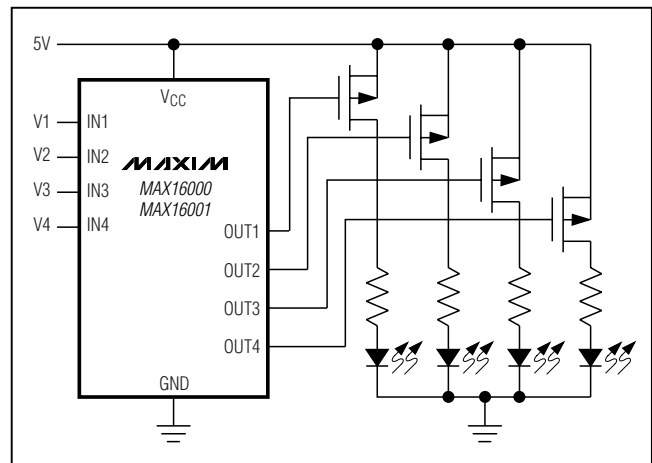

Figure 6. Quad Undervoltage Detector with LED Indicators

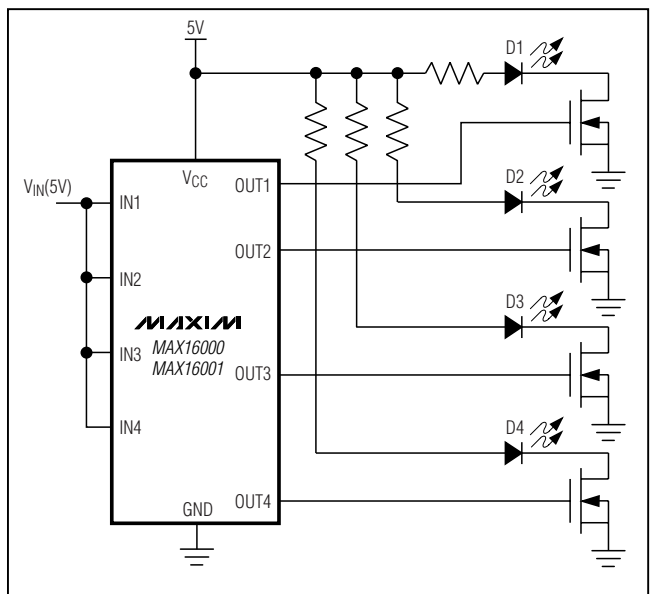

Figure 7. V_{CC} Bar-Graph Monitoring

Low-Voltage, Quad-/Hex-/Octal-Voltage μ P Supervisors in TQFN

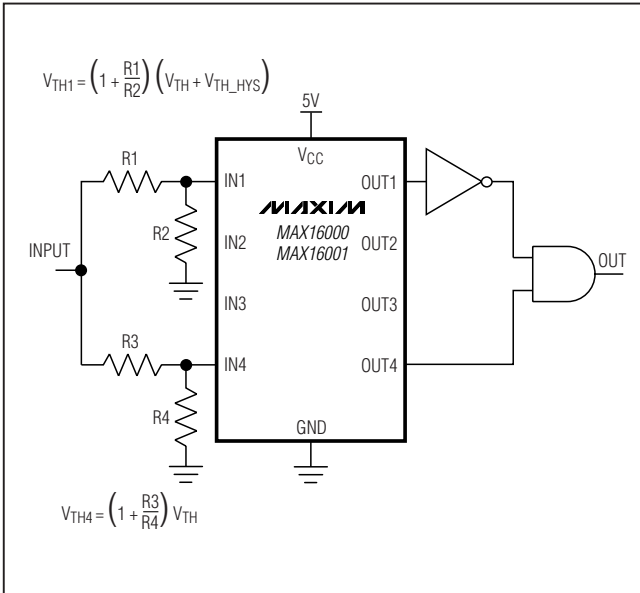

Figure 8. Window Detection

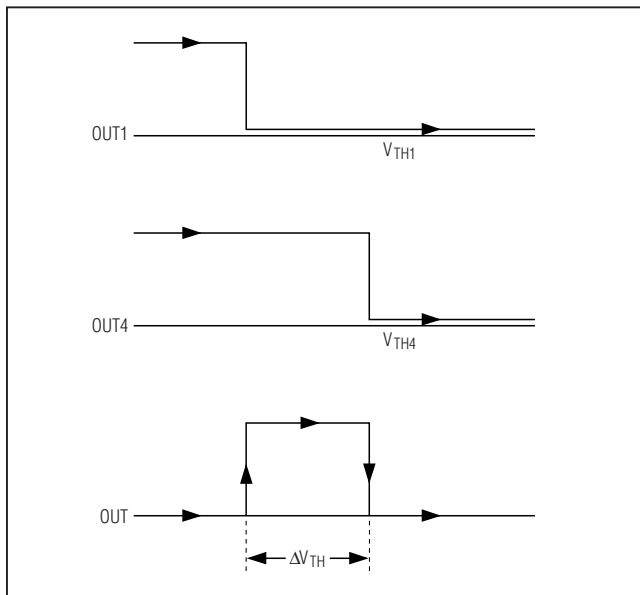

Figure 9. Output Response of Window Detector Circuit

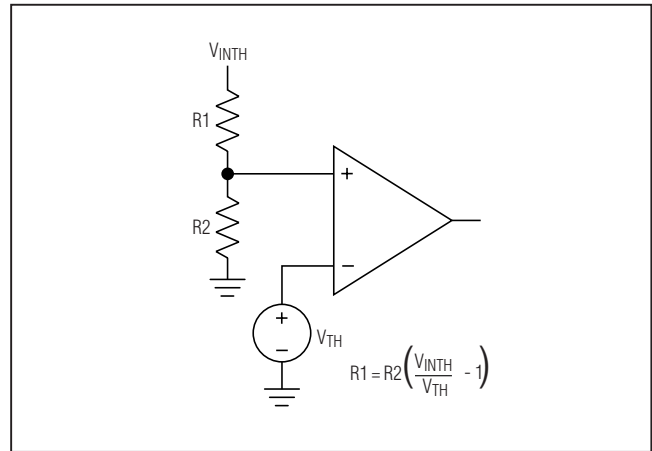

Figure 10. Setting the Adjustable Input

Adjustable Input

These devices offer several monitor options with adjustable input thresholds (see Table 1). The threshold voltage at each adjustable IN_ input is typically 0.394V (TOL = GND) or 0.372 (TOL = VCC). To monitor a voltage V_{INTH}, connect a resistive-divider network to the circuit as shown in Figure 10.

$$V_{INTH} = V_{TH} \left(\frac{R1}{R2} + 1 \right)$$

$$R1 = R2 \left(\frac{V_{INTH}}{V_{TH}} - 1 \right)$$

Large resistors can be used to minimize current through the external resistors. For greater accuracy, use lower-value resistors.

Unused Inputs

Connect any unused IN_ inputs to a voltage above its threshold.

OUT_ Outputs (MAX16000/MAX16001/MAX16003/ MAX16004/MAX16006)

The OUT_ outputs go low when their respective IN_ inputs drop below their specified thresholds. The output is open drain with a 30 μ A internal pullup to VCC. For many applications, no external pullup resistor is required to interface with other logic devices. An external pullup resistor to any voltage from 0 to 5.5V overrides the internal pullup if interfacing to different logic supply voltages. Internal circuitry prevents reverse current flow from the external pullup voltage to VCC (Figure 11).

Low-Voltage, Quad-/Hex-/Octal-Voltage μ P Supervisors in TQFN

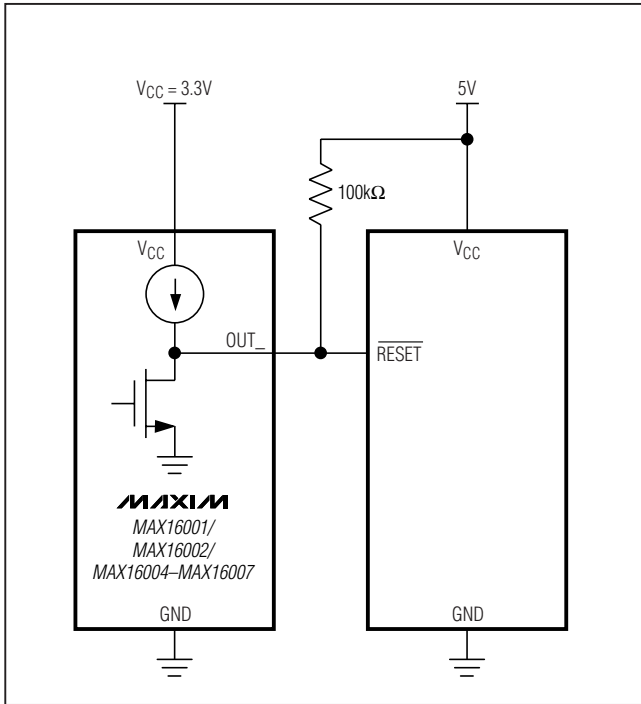

Figure 11. Interfacing to a Different Logic Supply Voltage

RESET Output (MAX16001/MAX16002/ MAX16004-MAX16007)

RESET asserts low when any of the monitored voltages fall below their respective thresholds or MR is asserted. RESET remains asserted for the reset timeout period after all monitored voltages exceed their respective thresholds and MR is deasserted (see Figure 12). This open-drain output has a 30 μ A internal pullup. An external pullup resistor to any voltage from 0 to 5.5V overrides the internal pullup if interfacing to different logic supply voltages. Internal circuitry prevents reverse current flow from the external pullup voltage to VCC (Figure 11).

WDO (MAX16005 Only)

WDO asserts low whenever the watchdog timer times out or any of the IN_ inputs falls below its respective threshold. WDO deasserts after a valid WDI transition without a reset timeout period. WDO deasserts without

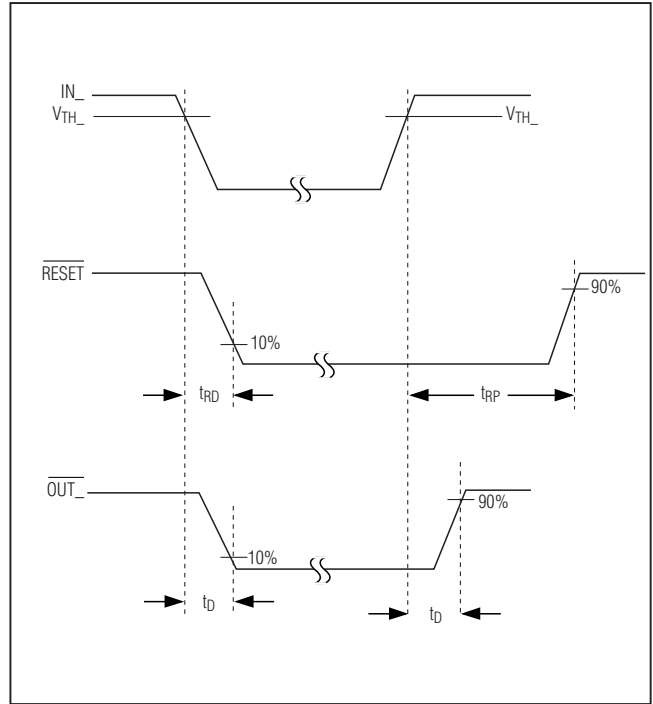

Figure 12. Output Timing Diagram

a timeout delay when all the IN_ inputs rise above their thresholds. Pull MR low to deassert WDO. WDO remains deasserted while MR is low. The watchdog timer begins counting after the reset timeout period after MR goes high. Pull MARGIN to deassert WDO.

Reset Timeout Capacitor

The reset timeout period can be adjusted to accommodate a variety of μ P applications from 50 μ s to 1.12s. Adjust the reset timeout period (t_{RP}) by connecting a capacitor (C_{SRT}) between SRT and GND. Calculate the reset timeout capacitor as follows:

$$C_{SRT}(F) = \frac{t_{RP}(s) \times I_{SRT}}{V_{TH_SRT}}$$

Connect SRT to VCC for a factory-programmed reset timeout of 140ms (min).

Low-Voltage, Quad-/Hex-/Octal-Voltage μ P Supervisors in TQFN

MAX16000–MAX16007

Manual Reset Input ($\overline{\text{MR}}$)

(MAX16001/MAX16002/MAX16004–MAX16007)

Many μ P-based products require manual reset capability, allowing the operator, a test technician, or external logic circuitry to initiate a reset. A logic-low on $\overline{\text{MR}}$ asserts $\overline{\text{RESET}}$ low. $\overline{\text{RESET}}$ remains asserted while $\overline{\text{MR}}$ is low, and during the reset timeout period (140ms min) after $\overline{\text{MR}}$ returns high. The $\overline{\text{MR}}$ input has an internal 20k Ω pullup resistor to V_{CC} , so it can be left unconnected if not used. $\overline{\text{MR}}$ can be driven with TTL or CMOS-logic levels, or with open-drain/collector outputs. Connect a normally open momentary switch from $\overline{\text{MR}}$ to GND to create a manual reset function. External debounce circuitry is not required. If $\overline{\text{MR}}$ is driven from long cables or if the device is used in a noisy environment, connecting a 0.1 μ F capacitor from $\overline{\text{MR}}$ to GND provides additional noise immunity.

Margin Output Disable ($\overline{\text{MARGIN}}$)

$\overline{\text{MARGIN}}$ allows system-level testing while power supplies are adjusted from their nominal voltages. Drive $\overline{\text{MARGIN}}$ low to force $\overline{\text{RESET}}$, $\overline{\text{WDO}}$, and $\overline{\text{OUT}}$ high, regardless of the voltage at any monitored input. The state of each output does not change while $\overline{\text{MARGIN}} = \text{GND}$. The watchdog timer continues to run when $\overline{\text{MARGIN}}$ is low, and if a timeout occurs, $\overline{\text{WDO}}/\overline{\text{RESET}}$ will assert t_{MD} after $\overline{\text{MARGIN}}$ is deasserted.

The $\overline{\text{MARGIN}}$ input is internally pulled up to V_{CC} . Leave $\overline{\text{MARGIN}}$ unconnected or connect to V_{CC} if unused.

Power-Supply Bypassing

The MAX16000–MAX16007 operate from a 2.0V to 5.5V supply. An undervoltage lockout ensures that the outputs are in the correct states when the UVLO is exceeded. In noisy applications, bypass V_{CC} to ground with a 0.1 μ F capacitor as close to the device as possible. The additional capacitor improves transient immunity. For fast-rising V_{CC} transients, additional capacitance may be required.

Ordering Information (continued)

PART	TEMP RANGE	PIN-PACKAGE	PKG CODE
MAX16001_TE+	-40°C to +125°C	16 TQFN-EP*	T1644-4
MAX16002_TC+	-40°C to +125°C	12 TQFN-EP*	T1244-4
MAX16003_TE+	-40°C to +125°C	16 TQFN-EP*	T1644-4
MAX16004_TP+	-40°C to +125°C	20 TQFN-EP*	T2044-3
MAX16005_TE+	-40°C to +125°C	16 TQFN-EP*	T1644-4
MAX16006_TG+	-40°C to +125°C	24 TQFN-EP*	T2444-4
MAX16007_TP+	-40°C to +125°C	20 TQFN-EP*	T2044-3

Note: The “_” is a placeholder for the input voltage threshold. See Table 1.

+Denotes lead-free package.

For tape-and-reel, add a “T” after the “+.” Tape-and-reel are offered in 2.5k increments.

*EP = Exposed paddle.

Selector Guide

PART	MONITORED VOLTAGES	INDEPENDENT OUTPUTS	$\overline{\text{RESET}}$	WDI/ $\overline{\text{WDO}}$	$\overline{\text{MR}}$	ADJUSTABLE RESET TIMEOUT
MAX16000	4	4	—	—	—	—
MAX16001	4	4	✓	WDI	✓	✓
MAX16002	4	—	✓	WDI	✓	✓
MAX16003	6	6	—	—	—	—
MAX16004	6	6	✓	WDI	✓	✓
MAX16005	6	—	✓	WDI/ $\overline{\text{WDO}}$	✓	✓
MAX16006	8	8	✓	WDI	✓	✓
MAX16007	8	—	✓	WDI	✓	✓

Revision History

Pages changed at Rev 2: 1, 4, 7, 9, 10, 20-24

Chip Information

PROCESS: BiCMOS

Low-Voltage, Quad-/Hex-/Octal-Voltage μ P Supervisors in TQFN

Pin Configurations

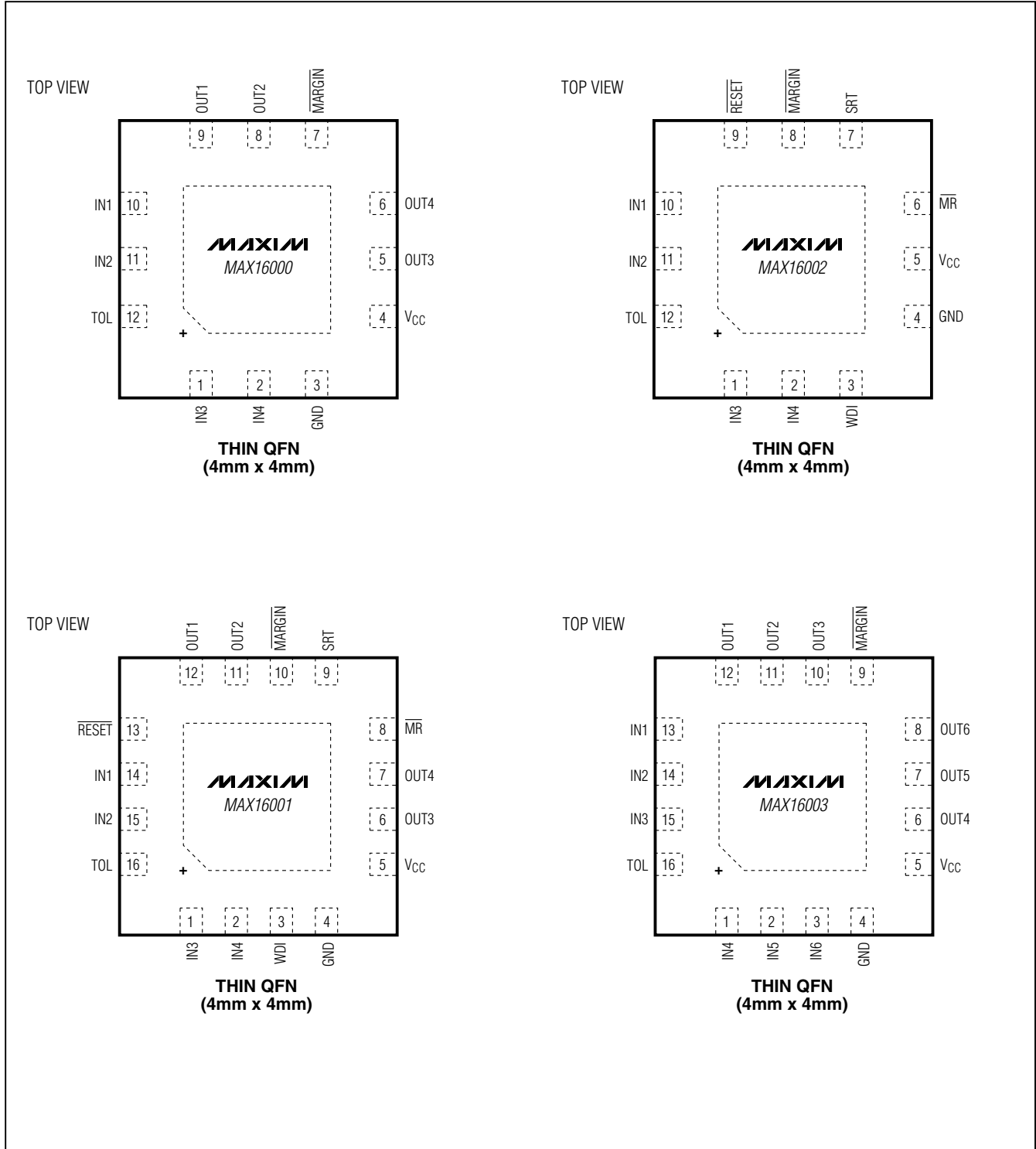

Low-Voltage, Quad-/Hex-/Octal-Voltage μ P Supervisors in TQFN

Pin Configurations (continued)

MAX16000-MAX16007

TOP VIEW

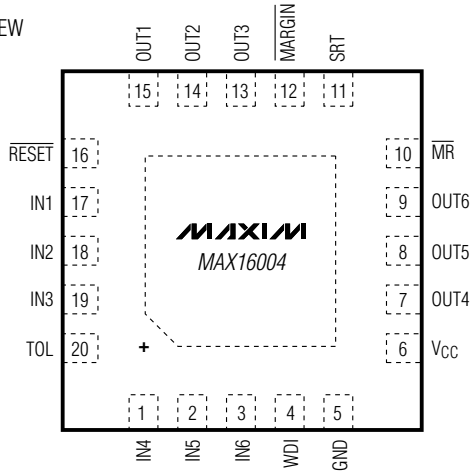

THIN QFN
(4mm x 4mm)

TOP VIEW

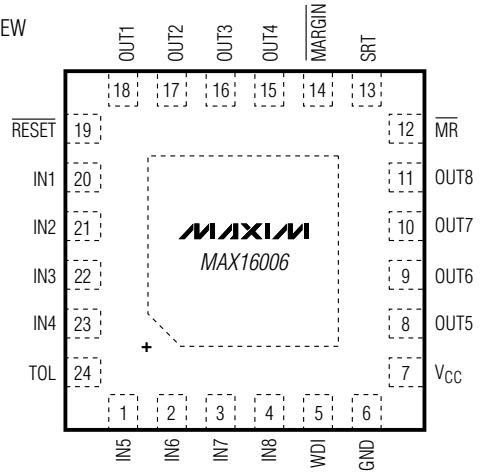

THIN QFN
(4mm x 4mm)

TOP VIEW

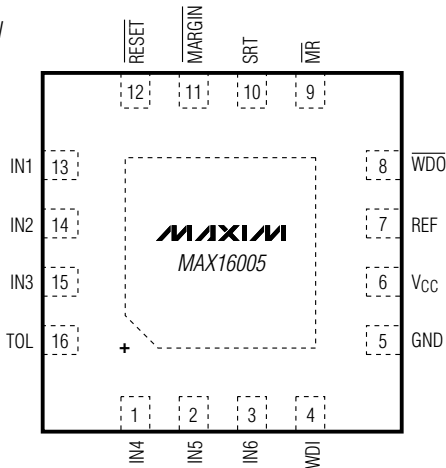

THIN QFN
(4mm x 4mm)

TOP VIEW

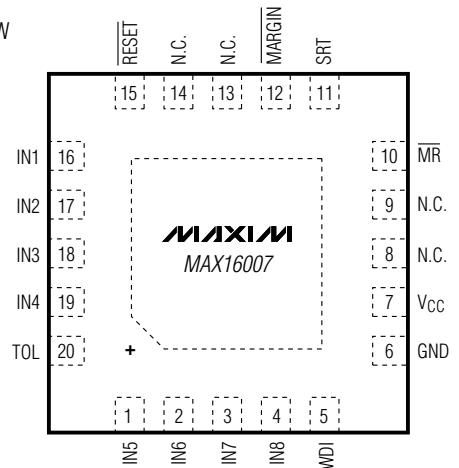

THIN QFN
(4mm x 4mm)

Low-Voltage, Quad-/Hex-/Octal-Voltage μ P Supervisors in TQFN

Package Information

(The package drawing(s) in this data sheet may not reflect the most current specifications. For the latest package outline information go to www.maxim-ic.com/packages.)

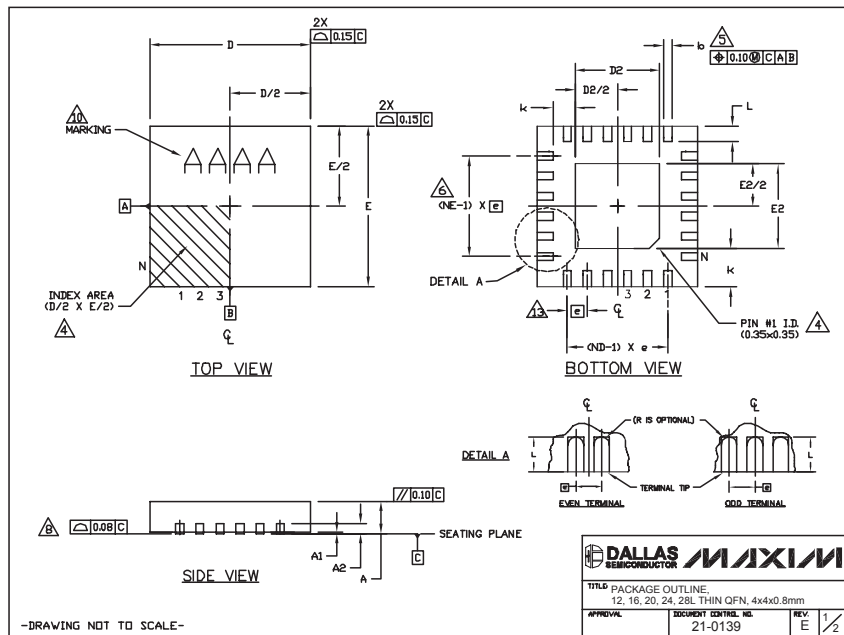

COMMON DIMENSIONS													EXPOSED PAD VARIATIONS										
PKG REF.	12L 4x4			16L 4x4			20L 4x4			24L 4x4			28L 4x4			PKG CODES	D2			E2			DOWN BOWS ALLOWED
	MIN.	NOM.	MAX.	MIN.	NOM.	MAX.	MIN.	NOM.	MAX.	MIN.	NOM.	MAX.	MIN.	NOM.	MAX.		MIN.	NOM.	MAX.	MIN.	NOM.	MAX.	
A	0.70	0.75	0.80	0.70	0.75	0.80	0.70	0.75	0.80	0.70	0.75	0.80	0.70	0.75	0.80	T1244-3	1.95	2.10	2.25	1.95	2.10	2.25	YES
A1	0.0	0.02	0.05	0.0	0.02	0.05	0.0	0.02	0.05	0.0	0.02	0.05	0.0	0.02	0.05	T1244-4	1.95	2.10	2.25	1.95	2.10	2.25	NO
AE	0.20 REF.			0.20 REF.			0.20 REF.			0.20 REF.			0.20 REF.			T1644-3	1.95	2.10	2.25	1.95	2.10	2.25	YES
b	0.25	0.30	0.35	0.25	0.30	0.35	0.20	0.25	0.30	0.18	0.23	0.30	0.15	0.20	0.25	T1644-4	1.95	2.10	2.25	1.95	2.10	2.25	NO
B	3.90	4.00	4.10	3.90	4.00	4.10	3.90	4.00	4.10	3.90	4.00	4.10	3.90	4.00	4.10	T2044-2	1.95	2.10	2.25	1.95	2.10	2.25	YES
E	3.90	4.00	4.10	3.90	4.00	4.10	3.90	4.00	4.10	3.90	4.00	4.10	3.90	4.00	4.10	T2044-3	1.95	2.10	2.25	1.95	2.10	2.25	NO
e	0.50 BSC.			0.50 BSC.			0.50 BSC.			0.50 BSC.			0.50 BSC.			T2444-2	1.95	2.10	2.25	1.95	2.10	2.25	YES
k	0.25	-	-	0.25	-	-	0.25	-	-	0.25	-	-	0.25	-	-	T2444-3	2.45	2.60	2.63	2.45	2.60	2.63	YES
L	0.45	0.55	0.65	0.45	0.55	0.65	0.45	0.55	0.65	0.30	0.40	0.50	0.30	0.40	0.50	T2444-4	2.45	2.60	2.63	2.45	2.60	2.63	NO
N	12			16			20			24			28			T2844-1	2.50	2.60	2.70	2.50	2.60	2.70	NO
ND	3			4			5			6			7										
NE	3			4			5			6			7										
VGGC		VGGB			VGGC			VGGD-1			VGGD-2			VGGE									

NOTES:

- DIMENSIONING & TOLERANCING CONFORM TO ASME Y14.5M-1994.
- ALL DIMENSIONS ARE IN MILLIMETERS. ANGLES ARE IN DEGREES.
- N IS THE TOTAL NUMBER OF TERMINALS.
- THE TERMINAL #1 IDENTIFIER AND TERMINAL NUMBERING CONVENTION SHALL CONFORM TO JEDEC 95-1 SP-012. DETAILS OF TERMINAL #1 IDENTIFIER ARE OPTIONAL, BUT MUST BE LOCATED WITHIN THE ZONE INDICATED. THE TERMINAL #1 IDENTIFIER MAY BE EITHER A MOLD OR MARKED FEATURE.
- DIMENSION b APPLIES TO METALLIZED TERMINAL AND IS MEASURED BETWEEN 0.25 mm AND 0.30 mm FROM TERMINAL TP.
- ND AND NE REFER TO THE NUMBER OF TERMINALS ON EACH D AND E SIDE RESPECTIVELY.
- DEPOPULATION IS POSSIBLE IN A SYMMETRICAL FASHION.
- COPLANARITY APPLIES TO THE EXPOSED HEAT SINK SLUG AS WELL AS THE TERMINALS.
- DRAWING CONFORMS TO JEDEC MO220, EXCEPT FOR T2444-3, T2444-4 AND T2844-1.
- MARKING IS FOR PACKAGE ORIENTATION REFERENCE ONLY.
- COPLANARITY SHALL NOT EXCEED 0.08mm
- WARPAGE SHALL NOT EXCEED 0.10mm
- LEAD CENTERLINES TO BE AT TRUE POSITION AS DEFINED BY BASIC DIMENSION "e", ± 0.05 .
- NUMBER OF LEADS SHOWN ARE FOR REFERENCE ONLY.

-DRAWING NOT TO SCALE-

Maxim cannot assume responsibility for use of any circuitry other than circuitry entirely embodied in a Maxim product. No circuit patent licenses are implied. Maxim reserves the right to change the circuitry and specifications without notice at any time.

24 Maxim Integrated Products, 120 San Gabriel Drive, Sunnyvale, CA 94086 408-737-7600